



# OBERDORFER®

An Ingersoll Rand Business

## RM103 METALLIC CHEMSTEEL SERIES

### SEAL-LESS MAGNETIC DRIVE



A full range of accessories are available including:

- line mounted pressure relief valves
- pump mounting foot for use with footless motors
- pedestal assembly

### Specific Solutions

Gear/bearing design allows for “trimming” for optimizing the pump’s maximum flow to reach minimum turndown or to match flow to a specific OEM’s requirement.

Special materials combinations are available for specific liquids:

- 316 stainless or Alloy C housing construction.
- Gears available in 316 stainless, W88 stainless and Alloy C. Also in Teflon®, Ryton® and PEEK®.
- Shafts are 316 stainless steel or Alloy C.
- Bearings available in Carbon, Teflon®, or Rulon®

MODEL	RM103	
MAXIMUM FLOW (GPM/LPM) @1750 RPM	1.5 GPM	5.67 LPM (0.34 m³/h)
THEORETICAL DISPLACEMENT	3.8 CC/REVOLUTION	
MAXIMUM DIFFERENTIAL PRESSURE	110 PSIG	7.6 BAR
MAXIMUM SYSTEM PRESSURE	300 PSIG	20.7 BAR
MAXIMUM SPEED	1800 RPM	
MAXIMUM FLUID TEMPERATURE	450° F	232° C
MINIMUM FLUID TEMPERATURE	-50° F	-46° C
NPSHR @ 1750	2 FEET	0.6 M
STANDARD PORT SIZE	1/4" FNPT	1/4" BSPT
WEIGHT-LESS MOTOR	13 LBS	5.9 KG

### Performance

Capacity water at 70° F / 21.2° C

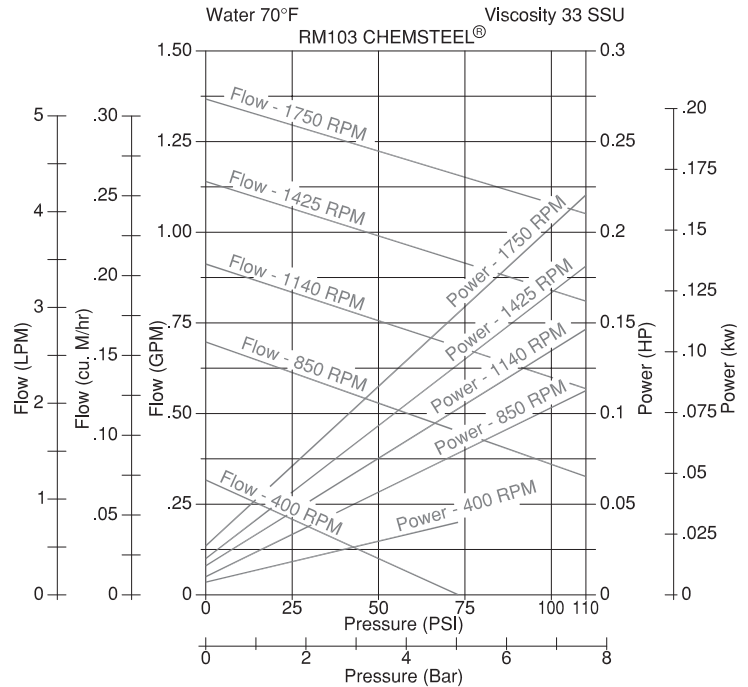

Notes: For continuous service:  
Plastic / Plastic gear combinations are limited to 50 psi or 3.5 bar.  
Metal / Plastic gear combinations are limited to 100 psi or 7 bar.

### General Description

Chemsteel pumps are designed to handle highly corrosive liquids that must be pumped under pressure. Manufactured to extremely precise tolerance, the Chemsteel pump line prevents system contamination while maintaining the purity and integrity of the liquid being pumped. Its rugged, three-section, o-ring sealed thru-bolt construction provides ease of servicing and parts replacement.

Helical gearing offers noise reduction by as much as 10db.

Additionally, Chemsteel pumps offer bi-directional operation for applications requiring reversing flow



**OBERDORFER**<sup>®</sup>

An Ingersoll Rand Business

## Fit

Connections are 1/4" female NPT or BSPT, pump hardware is metric and close couple adapters mount to both NEMA and IEC standard motor frame sizes for world wide acceptance. The port size is the same as competitive pumps.

## Maintenance

A three-part housing provides easy disassembly and service. Full size bearings match the gear diameter, and eliminate the need for separate wear plates. TFE encapsulating silicone o-ring pump housing seals provide elastic memory to assure an effective long lasting seal and thus avoiding the re-torquing required of pumps using pure TFE.

## Dimensions

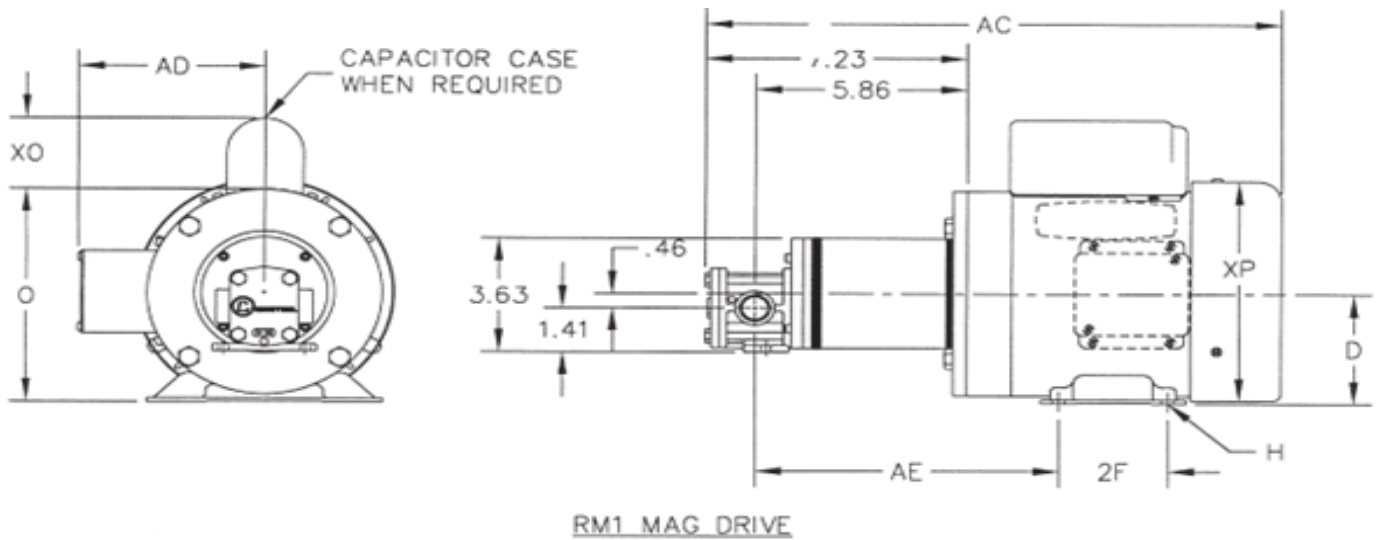

## Life Cycle/Cost of Ownership

Pump design and materials selection, together provide the longest life available from a gear pump. Key attributes include:

- Gear & bearing combinations of metallic and nonmetallic wear surfaces.
- Slotted bearings to lubricate shaft and gear surfaces.
- Hydraulic porting to balance axial thrust and to reduce wear.
- Ample port sizing to reduce the likelihood of cavitation when inlet pressure is marginal.
- Effective housing seals with elastic memory prevent leakage of corrosives.

To order a CHEMkit<sup>®</sup>, simply add a "K" to the end of the model number.

A repair kit contains the following parts: bearings, gears, o-rings, shafts, keys, c clips, and retaining ring.

MAG CHEMSTEEL OPTION SUFFIX	POWER KIT PART NO.	MOTOR FRAME		AC*	D	2F	H	AE	AD	*O	*XO	*XP
M1	OBMRIH56	56C	INCHES	15.98	3.50	3	.34 SLOT	8.42	5.31	6.81	2.25	7.16
			MILIMETERS	405.9	88.9	76.2	8.6 SLOT	213.9	134.9	173	57.2	181.9
M3	OBMRI7IE	IEC 71C, B14 FACE	INCHES	15.5	2.8	3.54	.28 SLOT	7.04	4.00	5.14	N/A	4.13
			MILIMETERS	393.7	71	89.9	7.1 SLOT	178.8	101.6	130.6	N/A	104.9
M4	OBMRIT80E	IEC 80C, B14 FACE	INCHES	17.15	3.15	3.94	.39 SLOT	8.22	4.51	6	N/A	4.72
			MILIMETERS	435.6	80	100.1	9.9 SLOT	208.8	114.6	152.4	N/A	119.9

\* Dimensions AC, O XO and XP may vary depending on HP, Enclosure, Speed and Manufacturer



12500 South Pulaski Road  
Alsip, IL 60803, USA  
Phone (800) 448.1668